

DRA05/10/18 SERIES



AC - DC DIN RAIL MOUNTABLE POWER SUPPLY
INDUSTRIAL CONTROL EQUIPMENT

FEATURES

- UNIVERSAL INPUT 90~264VAC
- SHORT CIRCUIT PROTECTION
- INTERNAL INPUT FILTER
- 3 YEARS WARRANTY



SELECTION CHART

DRA18- 24 x

Wattage ——— | ——— | ——— BLANK : SPRING TERMINAL TYPE
05 : 05V OUT 15 : 15V OUT A : SCREW TERMINAL TYPE
12 : 12V OUT 24 : 24V OUT

MODEL LIST

MODEL NO.	INPUT VOLTAGE	OUTPUT WATTAGE	OUTPUT VOLTAGE	OUTPUT CURRENT	EFF. (min.)	EFF. (typ.)
Single Output Models						
DRA05-05(A)	90~264 VAC	5 WATTS	+ 5 VDC	1 A	67%	69%
DRA05-12(A)	90~264 VAC	5 WATTS	+ 12 VDC	0.42 A	70%	72%
DRA05-15(A)	90~264 VAC	5 WATTS	+ 15 VDC	0.34 A	70%	72%
DRA05-24(A)	90~264 VAC	5 WATTS	+ 24 VDC	0.21 A	70%	72%
DRA10-05(A)	90~264 VAC	10 WATTS	+ 5 VDC	2 A	71%	73%
DRA10-12(A)	90~264 VAC	10 WATTS	+ 12 VDC	0.84 A	73%	75%
DRA10-15(A)	90~264 VAC	10 WATTS	+ 15 VDC	0.67 A	74%	76%
DRA10-24(A)	90~264 VAC	10 WATTS	+ 24 VDC	0.42 A	74%	76%
DRA18-05(A)	90~264 VAC	15 WATTS	+ 5 VDC	3 A	73%	75%
DRA18-12(A)	90~264 VAC	18 WATTS	+ 12 VDC	1.5 A	75%	77%
DRA18-15(A)	90~264 VAC	18 WATTS	+ 15 VDC	1.2 A	75%	77%
DRA18-24(A)	90~264 VAC	18 WATTS	+ 24 VDC	0.75 A	75%	77%

SPECIFICATION

All Specifications Typical At Nominal Line, Full Load, 25°C Unless Otherwise Noticed

GENERAL						
Characteristics	Conditions	min.	typ.	max.	unit	
Switching frequency	Vi nom, Io nom		132		KHz	
Isolation voltage	Input-Output	3,000 / 4,242			VAC / VDC	
	Input-PE	1,768 / 2,500			VAC / VDC	
	Output-PE	500 / 710			VAC / VDC	
Isolation resistance	Input-Output, @ 500VDC	100			MΩ	
Ambient temperature	Operating at Vi nom	-20		+ 71	°C	

DRA05/10/18 SERIES

SPECIFICATION

All Specifications Typical At Nominal Line, Full Load, 25°C Unless Otherwise Noticed

GENERAL						
Characteristics	Conditions		min.	typ.	max.	unit
Derating (see derating curve)	Vi nom, from +61°C to +71°C				2.5	% / °C
Storage temperature	Non operational		-25		+ 85	°C
Relative humidity	Vi nom, lo nom		20		95	% RH
Temperature coefficient	Vi nom, lo min				± 0.03	% / °C
MTBF	DRA05 Bellcore Issue 6 @40°C, GB	5V		806,000		Hours
		12V		831,000		Hours
		15V		846,000		Hours
		24V		888,000		Hours
	DRA10 Bellcore Issue 6 @40°C, GB	5V		728,000		Hours
		12V		767,000		Hours
		15V		780,000		Hours
		24V		808,000		Hours
	DRA18 Bellcore Issue 6 @40°C, GB	5V		704,000		Hours
		12V		721,000		Hours
		15V		735,000		Hours
		24V		764,000		Hours
Altitude during operation	EN 62368-1				5,000	m
Dimension	Spring & Screw terminal type		L90 x W22.5 x D114			mm
Cooling	Free air convection					
Installation position	Vertical (other direction may derating using)					
Pollution degree			2			

INPUT SPECIFICATIONS						
Characteristics	Conditions		min.	typ.	max.	unit
Rated input voltage	lo nom		100		240	VAC
Absolute input max. range	Ta min ... Ta max, lo nom	AC in	90		264	VAC
		DC in	120		375	VDC
Input current	Vi : 115 / 230 VAC, lo nom	DRA05		115 / 80		mA
		DRA10		200 / 130		mA
		DRA18		335 / 210		mA
Rated input current	Vi : 90 VAC, lo nom	DRA05			200	mA
		DRA10			300	mA
		DRA18			500	mA
Line frequency	Vi nom, lo nom		47		63	Hz
Inrush current	Vi : 115 / 230 VAC , lo nom				15 / 30	A
Power dissipation	DRA05 Vi : 230 VAC, lo nom	5V		2.2		W
		12V		1.9		W
		15V		2.1		W
		24V		1.8		W
	DRA10 Vi : 230 VAC, lo nom	5V		4.0		W
		12V		3.4		W
		15V		3.3		W
		24V		2.8		W
	DRA18 Vi : 230 VAC, lo nom	5V		5.0		W
		12V		4.65		W
		15V		4.25		W
		24V		4.45		W
Leakage current	Input-Output				0.25	mA
	Input-PE				3.5	mA

OUTPUT SPECIFICATIONS						
Characteristics	Conditions		min.	typ.	max.	unit
Output voltage accuracy (Adjusted before shipment)	Vi nom, lo max		0		+ 1	%
Minimum load	Vi nom		0			%
Line regulation	lo nom, Vi min ...Vi max				± 1	%



DRA05/10/18 SERIES

SPECIFICATION

All Specifications Typical At Nominal Line, Full Load, 25°C Unless Otherwise Noticed

OUTPUT SPECIFICATIONS

Characteristics	Conditions	min.	typ.	max.	unit
Load regulation	Vi nom, lo min ...lo nom			± 2	%
Voltage trim range	Vi nom, 0.8 lo nom	5V	4.5	5.75	V
		12V	10.8	13.8	V
		15V	13.5	17.25	V
		24V	21.6	28.8	V
Rated continuous loading	DRA05 series Vi nom	5V	1.0 A @ 5Vdc / 0.85 A @ 5.75 Vdc		
		12V	0.42 A @ 12Vdc / 0.36 A @ 13.8 Vdc		
		15V	0.34 A @ 15Vdc / 0.28 A @ 17.25 Vdc		
		24V	0.21 A @ 24Vdc / 0.17 A @ 2 8.8 Vdc		
	DRA10 series Vi nom	5V	2 A @ 5Vdc / 1.7 A @ 5.75 Vdc		
		12V	0.84 A @ 12Vdc / 0.72 A @ 13.8 Vdc		
		15V	0.67 A @ 15Vdc / 0.58 A @ 17.25 Vdc		
		24V	0.42 A @ 24Vdc / 0.34 A @ 2 8.8 Vdc		
	DRA18 series Vi nom	5V	3 A @ 5Vdc / 2.6 A @ 5.75 Vdc		
		12V	1.5 A @ 12Vdc / 1.3 A @ 13.8 Vdc		
		15V	1.2 A @ 15Vdc / 1.0 A @ 17.25 Vdc		
		24V	0.75 A @ 24Vdc / 0.6 A @ 2 8.8 Vdc		
Hold up time	Vi : 115 / 230 VAC , lo nom	DRA05	30 / 130		ms
		DRA10	25 / 100		ms
		DRA18	20 / 75		ms
Turn on time	Vi nom, lo nom	DRA05 & DRA10		1,000	ms
	Vi nom, lo nom → with 3500 μF CAP			1,500	ms
	Vi nom, lo nom	DRA18		1,000	ms
	Vi nom, lo nom → with 7000 μF CAP			1,500	ms
Rise time	Vi nom, lo nom	DRA05 & DRA10		150	ms
	Vi nom, lo nom → with 3500 μF CAP			500	ms
	Vi nom, lo nom	DRA18		150	ms
	Vi nom, lo nom → with 7000 μF CAP			500	ms
Fall time	Vi nom, lo nom			150	ms
Transient recovery time	Vi nom, I ~0.5 lo nom			2	ms
Ripple & noise	Vi nom, lo nom, BW = 20MHz			50	mV
Power back immunity	Vi nom, lo nom 1 second	5V	7.5		VDC
		12V	18		VDC
		15V	22		VDC
		24V	35		VDC
Capacitor load	Vi nom, lo nom	DRA05 & DRA10		3,500	μF
		DRA18		7,000	μF
DC ON indicator threshold at start up (Green LED)	Vi nom, lo nom	5V	3.5	4.5	VDC
		12V	9.0	10.8	VDC
		15V	11.0	13.5	VDC
		24V	18	21.6	VDC
DC LOW indicator threshold after start up (Red LED)	Vi nom, lo nom	5V	3.5	4.5	VDC
		12V	9.0	10.8	VDC
		15V	11.0	13.5	VDC
		24V	18	21.6	VDC
Efficiency	Vi nom, lo nom, Po / Pi	Up to 77%, See model list and typ efficiency curve			

CONTROL AND PROTECTION

Characteristics	Conditions	min.	typ.	max.	unit
Input fuse		T2A / 250VAC internal			
Internal surge voltage protection	IEC 61000-4-5	Varistor			
Rated over current protection	Vi nom (see typ current limited curve)	110		165	%
Over voltage protection	Vi nom, 0.8 lo nom (Auto Recovery)	5V	6.25	7.25	V
		12V	15	17.4	V

DRA05/10/18 SERIES

SPECIFICATION

All Specifications Typical At Nominal Line, Full Load, 25°C Unless Otherwise Noticed

CONTROL AND PROTECTION

Characteristics	Conditions	min.	typ.	max.	unit
Over voltage protection	Vi nom, 0.8 Io nom (Auto Recovery)	15V	18.75	21.75	V
		24V	30	34.8	V
Output short circuit		Hiccup mode			
Degree of protection		IP20			

APPROVALS AND STANDARDS

UL / cUL	UL 508 Listed UL 60950-1, UL 1310 Class 2 Power Recognized ISA 12.12.01(Class I, Division 2, Groups A, B, C and D)
TUV	BS EN / EN 62368-1
cTUVus	UL 62368-1
CE	BS EN / EN 61000-6-3, BS EN / EN 55032 Class B, BS EN / EN 61000-3-2, BS EN / EN 61000-3-3 BS EN / EN 61000-6-2, BS EN / EN 55035, BS EN / EN 61000-4-2 Level 4, BS EN / EN 61000-4-3 Level 3 BS EN / EN 61000-4-4 Level 4, BS EN / EN 61000-4-5 Level 4 BS EN / EN 61000-4-6 Level 3, BS EN / EN 61000-4-8 Level 4, BS EN / EN 61000-4-11 DD ENV / ENV 50204 Level 2, BS EN / EN 61204-3, CISPR 32
CCC	GB4943.1, GB/T9254.1, GB17625.1
Vibration resistance	meet IEC 60068-2-6 (Mounting on rail : 10-500 Hz, 2G, along X, Y, Z each Axis, 60 min for each Axis)
Shock resistance	meet IEC 60068-2-27 (15G, 11ms, 3 Axis, 6 Faces, 3 times for each Face)

PHYSICAL CHARACTERISTICS

Case size	90 x 22.5 x 114 mm (3.6 x 0.89 x 4.49 inches)
Case material	Plastic
Weight	DRA05 & DRA10 : 120 g DRA18 : 150 g
Packing	DRA05 & DRA10 : 0.21 kg ; 56 pcs / 12.5 kg / 2.16 CUFT DRA18 : 0.23 kg ; 56 pcs / 14 kg / 2.16 CUFT

MECHANISM & PIN CONFIGURATION

mm [inch]

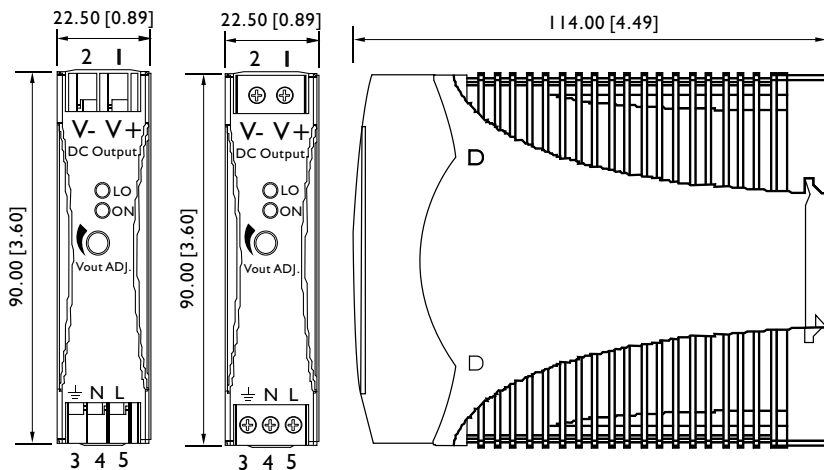

CONSTRUCTION

Easy snap-on mounting onto the DIN-Rail (TS35/7.5 or TS35/15), unit sits safely and firmly on the rail.

INSTALLATION

Ventilation / Cooling
Normal convection
All sides 25mm free space
For cooling recommended
Connector size range
Spring terminal:
AWG24-14 (0.2~2mm²) flexible / solid cable,
10 m/m stripping at cable end recommends
Screw terminal:
AWG26-12 (0.2~2.5mm²) flexible / solid cable,
connector can withstand torque at maximum 5 pound-inches.
4-5 m/m stripping at cable end recommends
Use copper conductors only, 60 / 75°C

GENERAL TOLERANCE	
0.00[0.00] - 30.00[1.18]	±0.30[0.01]
30.00[1.18] - 120.00[4.72]	±0.50[0.02]

PIN ASSIGNMENT

PIN NO.	Designation	Description
1	V +	Positive output terminal
2	V -	Negative output terminal
3	⊥	Ground this terminal to minimize high-frequency emissions
4	N	Input terminals (neutral conductor, no polarity at DC input)
5	L	Input terminals (phase conductor, no polarity at DC input)
	ON	Operation indicator LED
	LO	DC LOW indicator LED
	Vout ADJ.	Trimmer-potentiometer for Vout adjustment

CIRCUIT SCHEMATIC

• Block diagram

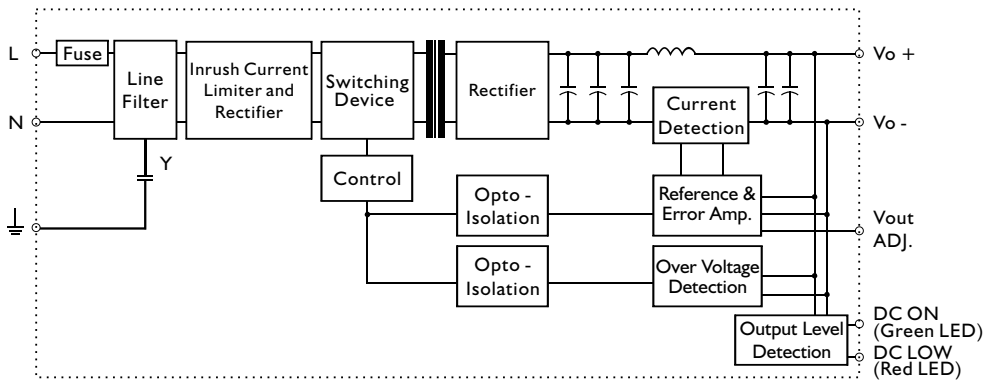

TYP. CURRENT LIMITED CURVE

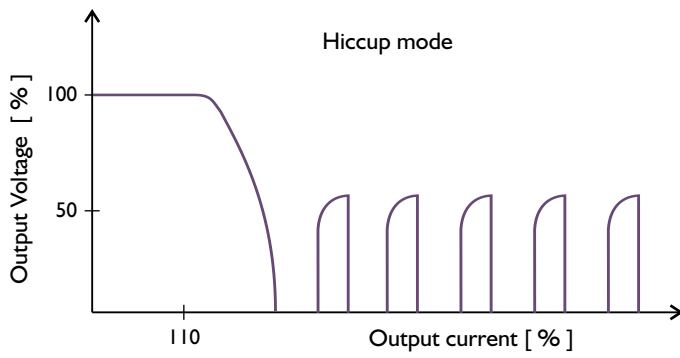

DERATING CURVE

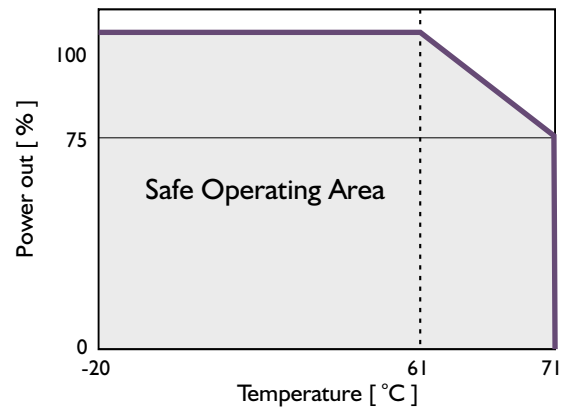

TYP. EFFICIENCY CURVE

